

# MRP

## - Exhaust Rail System

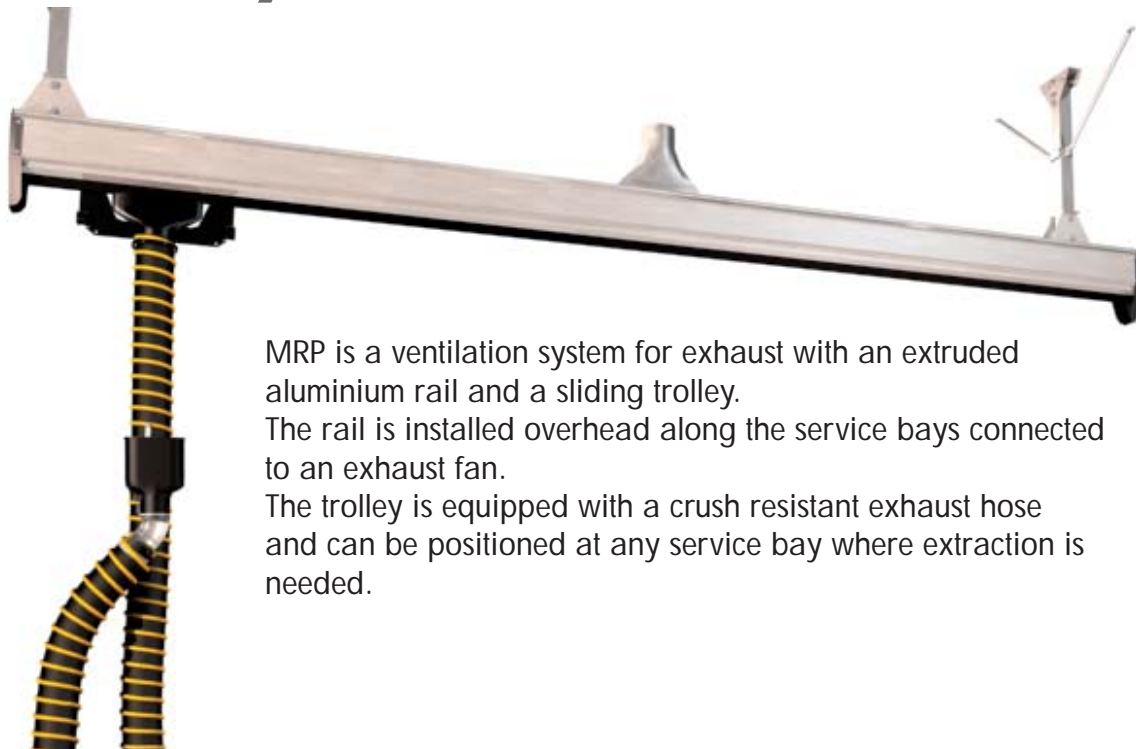

MRP is a ventilation system for exhaust with an extruded aluminium rail and a sliding trolley. The rail is installed overhead along the service bays connected to an exhaust fan. The trolley is equipped with a crush resistant exhaust hose and can be positioned at any service bay where extraction is needed.

### DESCRIPTION



**MRP-5,8 MRP-2,9**  
Canalina in alluminio  
L= 5,8m e 2,9m



**MRP-S**  
Giunto per canalina



**RSL-X**  
Guarnizione in gomma



**MRP-EC**  
Terminale cieco



**MRP-CE125**  
Terminale con raccordo  
Ø125mm



**MIC-100**  
Carrello interno



**TRS-00**  
Strumento per inserimento gomma



**MRP-HS**  
Gancio appendi-tubo



**REG-100-115**  
Bocchetta in gomma  
con morsetto



**EH-PV-100-5**  
Tubo L=5m



**RRDC-200**  
Raccordo diam.200mm, per aspirazione in centro alla canalina

## ACCESSORI - per info AIRUM T 051 60 25 072



**Balancer**  
BRL-300



**Suspension Belt**  
512616

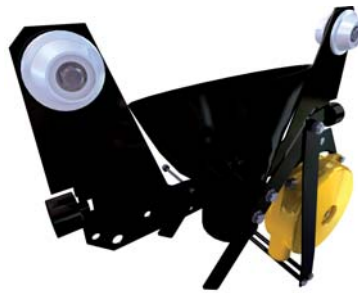

**Damper for balancer**  
MRP-BD



**Damper for hook**  
MRP-D

## DESCRIPTION

Binario:	6-18m.	Carrello:	Interno (con cuscinetti).
Materiale:	Alluminio estruso.	Bocca:	In gomma con foro per sonda CO.
Guarnizione:	Gomma EPDM a basso attrito.	Bilanciatore :	Portata 7-14kg con fermo e 3 m di cavo
Tubo:	Temperatura +150° C. Diam 100mm L= 5m.	(accessorio)	

## DIMENSIONAL DATA

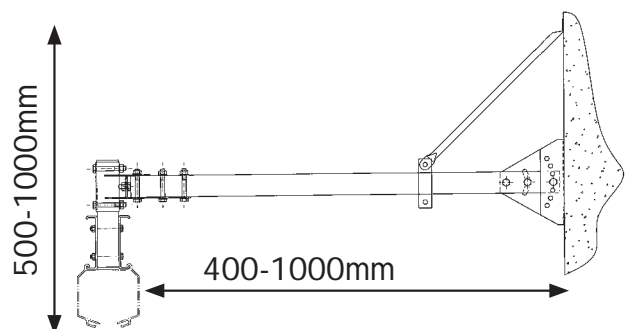
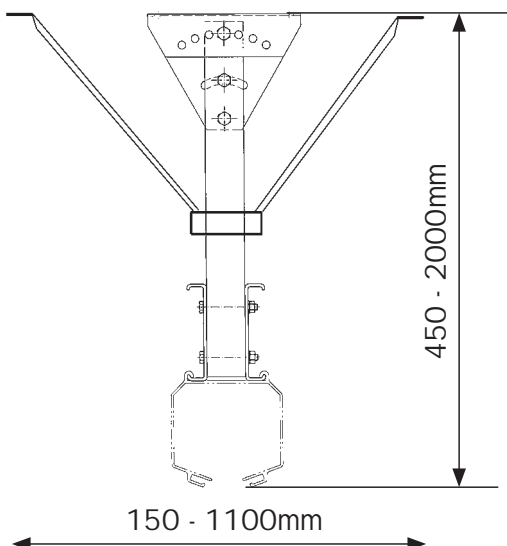
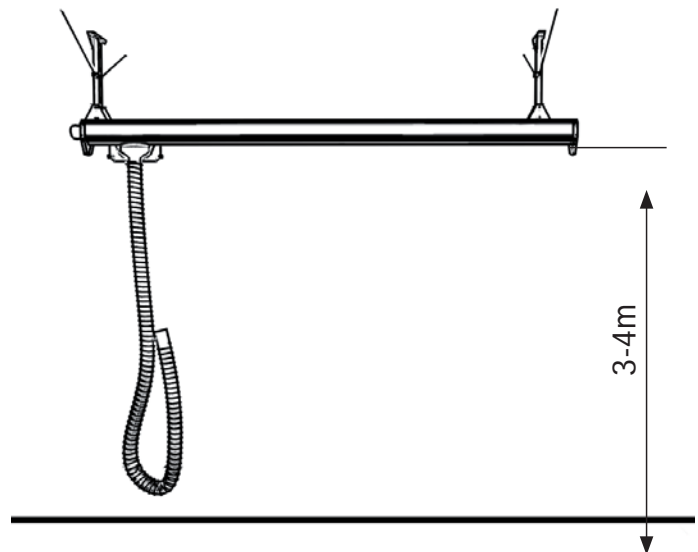
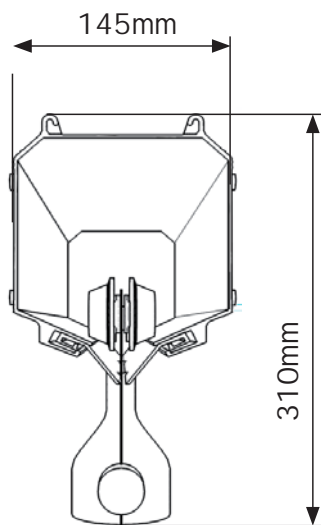

**MRP-MKV**

This is used to mount the SBT-SL support leg profile to the ceiling of your workshop. The suspension plate is adjustable for angled ceilings to adjust the pitch to vertical. Comes in sets to mount one support length.

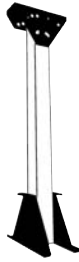

**SBT-SL**

This is an aluminium profile, extremely strong but light-weight for easy mounting. The profile comes in 5.8 m/19 ft and is cut to fit your application. Is sold by the piece or in packs of 24 pcs for large jobs



**MRP-MKH**

This is used to mount the SBT-SL support leg profile to the wall of your workshop. The horizontal slide plate will allow adjustment away from or closer to the wall. Comes in sets for mounting one support suspension.

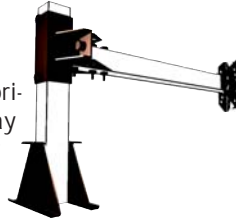

**SBT-SBK**

The SBT-SBK is designed to work with the SBT-SL profile to eliminate side movement of support legs. Comes in three lengths (430 mm/17", 710 mm/28" or 1830 mm/72") to handle any ceiling height or angle.

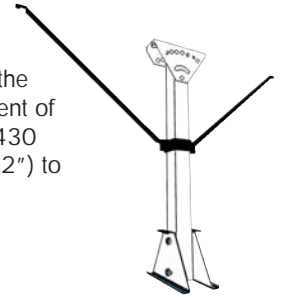

## PRESSURE DROP

Pressure drop for crab with 5m hose and nozzle.

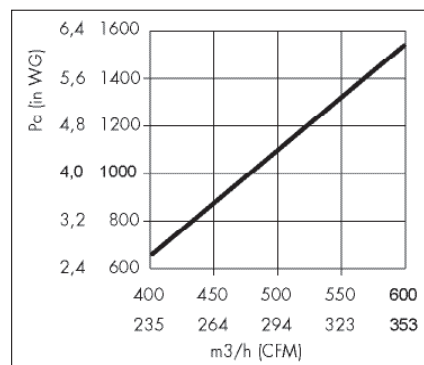

Pressure drop per metre for rail.

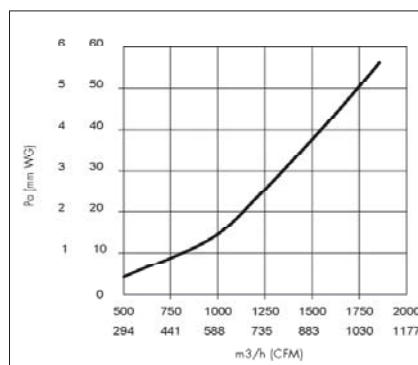

Pressure drop for connection.

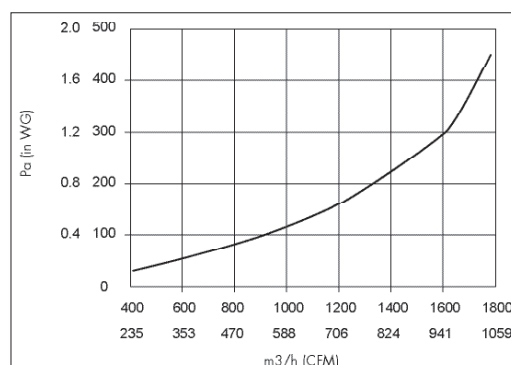

## SELECTION GUIDE

### Choose length of rail

The rail is available in 2,9 m (**MRP-2,9**) and 5,8 m (**MRP-5,8**)

### Choose length of rubber seal

For each metre of rail you need the double length of rubber seal. The rubber seal (**RSL-X**) is delivered in the length you need. For easy installation use the tool (**TRS-00**)

### Choose number of rail splice

The rail splice (**MRP-S**) joins two rails.

### Choose suspensions

We recommend maximum 5 m between suspensions.

### Choose number of trolleys

For each trolley you need the trolley itself (**MIC-100**), hose (**EH-PV-100-5**), nozzle (**REG-100-115**) and hose storage (**MRP-HS**).

### Choose hose storage

As an alternative to hose storage (**MRP-HS**) you can have a balancer (**BRL-300**) and a suspension belt. PlymoVent also offers a range of different hoses and nozzles for a variety of applications. Contact us for more information.

Automatic Dampers are available for both "hose storage" (**MRP-HS**) and "balancer" (**BRL-300**).

MRP-HS = MRP-D

BRL-300 = MRP-BD

### Choose duct connection

Choose between top connection (**RRDC-200**) or end connection (**MRP-CE125**). For 1 or 2 trolleys you can use end or top connection. Use top connection for 3 trolleys. For larger installations, please, contact PlymoVent.

### Choose number of end stops

You need one end stop (**MRP-EC**) if you have end connection and two if you have top connection.

### Choose fan

Recommended air volume for car and LCV repair shops is 360 m<sup>3</sup>/h. With this air volume you select a PlymoVent fan as below:

Numbers of trolleys:	Fan
1	FUA 1300
2	FUA 2100
3	TEV 585

**PLYMOVENT**<sup>®</sup>  
INTELLIGENT PROCESS VENTILATION™

Importatore in esclusiva per l'Italia  
AIRUM - BOLOGNA - tel 051 60 25 072  
www.airum.com

PlymoVent representative